

GEN 3 PISTOL CALIBER QRB INSTRUCTIONS

Always check to make sure any weapon you are working on is unloaded

The QRB Kit can only be used on Barrels with a maximum outside diameter of 0.985" and QRB Kit adds 1.5" to Free Float Hand Guards with a maximum width of 2.0"

Tools needed for the install: a barrel nut wrench, a set of Allen Keys, a small scaled ruler (or calipers) and an Upper Vise Block or equivalent. A bottle of Loctite 242 or equivalent is highly recommended.

NOTE: Make sure your barrel goes smoothly into the upper receiver before starting install. If there is resistance or tightness, address these issues before beginning. The barrel must easily slide in/out for a successful install.

1. Starting with a bare Upper Receiver, install the Charging Handle and Bolt Carrier. This is used for alignment of the 2-piece gas system.
2. Install the **Receiver Plate alignment** Pin into the Upper Receiver with the flat area facing the threads of the upper receiver.
3. Install the Receiver Plate onto the Upper Receiver and Gas Tube Extension the Star Nut recess away from the receiver. Make sure the flat area of the Gas Tube Extension lines up with the Receiver Plate cut out (Parallel with the Receiver threads).
4. Lightly oil the threads and outside of the Star Nut and install on the Receiver threads and hand tighten. Make sure the Gas Tube Extension flat is lined up to form a complete circle or binding will occur. Once you have the Star Nut Hand tight flush with the Receiver Plate, using your barrel nut Wrench center one of the Star Nut grooves with the Gas Tube Extension hole. GEN3 allows you set use Less than 30 ft/lbs TORQUE on Star Nut this allows you adjust Tightness of Barrel removal Tension Use the Gas Tube to check for clearance and alignment. See the Star Nut alignment graphic on the back of these instructions. Do not exceed **30 ft/lbs** of force for the alignment.
- 4A. Once Star Nut is installed apply Loctite 242 to **Locking Set Screw Tighten until Snug you do not need to Torque it**
5. Remove the Bolt Carrier and install your stripped barrel into the receiver extension. Make sure to line up the barrel's alignment pin with the groove in the Receiver and push in till flush.
6. Install the Barrel Plate over the muzzle end of the barrel. Slide the Barrel Plate down the barrel, making sure to align the pin on the Barrel Plate with the hole in the Receiver Plate. Make sure to keep the Hooks clear from the assemblies while installing.
7. Locate the tension screws on the back of the Hooks. Remove and apply Loctite 242 and re-install. Engage Hooks into the slots of the Receiver Plate. Place tension on both Levers towards the barrel till slight resistance is felt then adjust one screw until the tip of the Lever is 1.65" to 1.75" from the center of the barrel and repeat for the other side. A diagram of this adjustment is provided on the back of these instructions. Once this adjustment is done on both sides, the Levers can be set into their locked positions by pushing in towards the barrel. You should feel them "snap" into the lock position as they move towards the barrel. Unlock/lock a few times and adjust if necessary. Let set per Loctite's instructions.
8. Once the Levers have been adjusted properly, you may tighten the center screw at the bottom of the Barrel Plate to **40 in/lbs**, then tighten the two remaining screws at the top of the Barrel Plate to **40 in/lbs**. You may use the Loctite 242 to keep secure.
9. Install the supplied gas tube into your gas block then assemble your Free Float Hand Guards and gas tube assembly following the manufactures instructions. This should be done with at least one Lever engaged. Do not exceed **30 ft/lbs** of force while tightening Free Float Hand Guards on the Barrel Plate. If your Free Float Hand Guard is equipped with alignment tabs, the Face of the Barrel Plate has been machined for those to be used. If Free Float Hand Guards fail to tighten on barrel plate, use supplied washer to take up excessive space or Loctite in place. If Loctite was used, let set per Loctite's instructions.

You are now ready to test fire your QRB equipped rifle.

Both Levers must be locked when firing

General Parts Layout

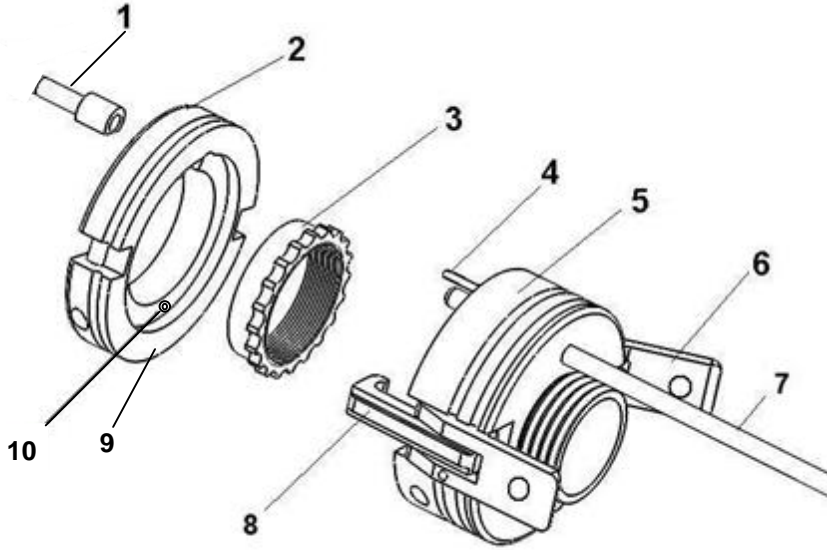

1. Receiver Plate Alignment Pin
2. Receiver Plate
3. Star Nut
4. Barrel Plate Alignment Pin
5. Barrel Plate
6. Lever
7. **Gas Tube (Not used in Blow Back)**
8. Hook
9. Star Nut Recess (for reference)
10. Locking set screw

Star Nut Alignment

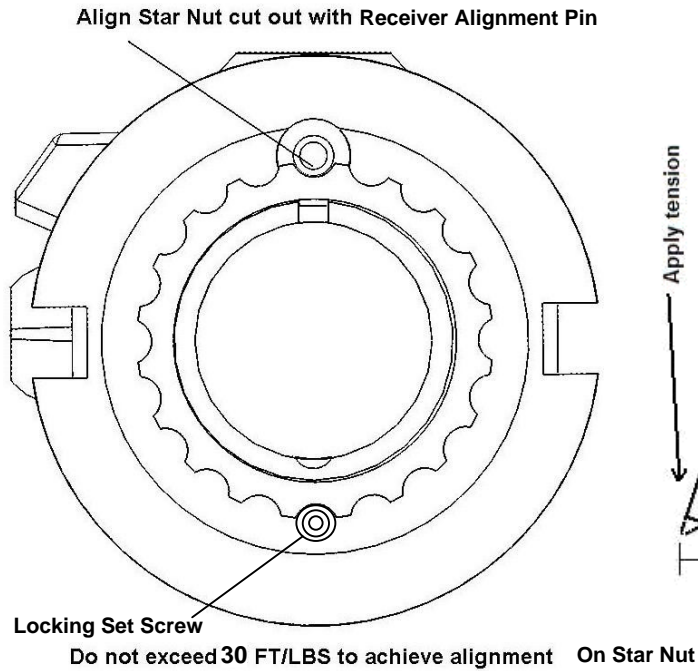

Top View of Tension Adjustment

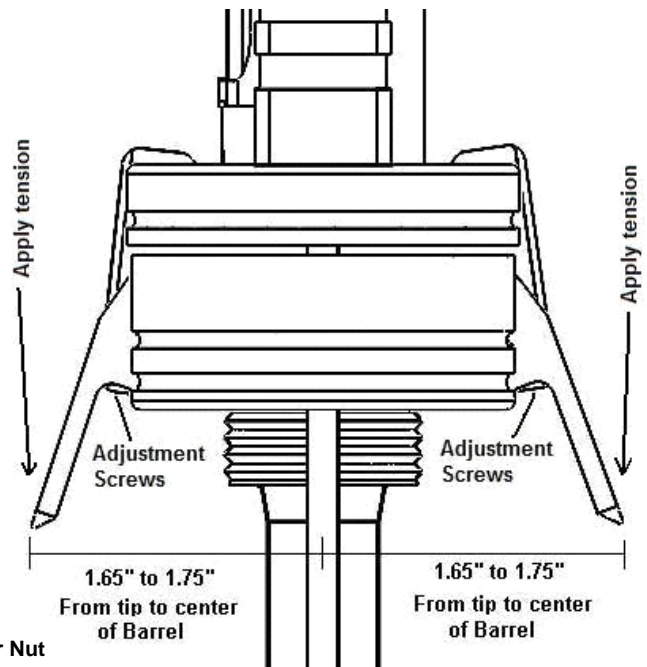

FOLLOW THESE SPECIFICATIONS OR DAMAGE WILL OCCUR

User assumes all responsibility for use of this product. No warranty is expressed or implied.

All Text and Images are Copyrighted 2017 Pat. No. 9,476,663

See our website for additional information and videos: www.CRYHAVOCTACTICAL.com